



Goliath Guillotine

TOPSIDE AND SUB-SEA CUTTING APPLICATIONS
16" THRU 32" (406-813MM) PIPE

FAST, SQUARE CUTS

Wachs Goliath Guillotine has been designed to cold cut 16" to 32" (406-813mm) pipe of all materials, as well as solids, and multi-stranded casing strings. Along with its durable sub-sea design, Goliath provides easy set up and fast accurate cuts.

VERTICAL OR HORIZONTAL MOUNTING

The fabricated steel mounting saddle assures square cuts at right angles. The Goliath can be mounted in any position around the pipe. Integrated lifting attachments allow for horizontal as well as vertical positioning. The Goliath cuts equally well on vertical and horizontal piping. The heavy-duty clamping chain system secures it firmly to the pipe.

HYDRAULIC DRIVE AND FEED SYSTEM

The Goliath Guillotine features a twin hydraulic drive and mechanical feed system, which allows for manual and automatic feed control. The automatic feed design offers two feed settings. A 16" diameter 3/4" wall steel pipe is cut in only 24 minutes. A 32" diameter multi-stranded casing string is cut in about 48 minutes.

BUILT FOR SERVICING THE OFFSHORE INDUSTRY

The Goliath Guillotine incorporates corrosion treated steel components, chromed and ground steel guide rods, self lubricated bushings, bearings and seals and wipers. The addition of wipers and seals protect the moving parts from the abrasive effects of casing string grout. The self lubricating bearings and bushings allow the Goliath to operate sub-sea without worry of saltwater solvent washing away moving part or slide lubrication.



SPECIFICATIONS:

Capacity: Cold cut all pipe material. 16"-32" (406-810mm) pipe

Wall Thickness: Any wall thickness

Clamping System: Chain clamping

Feed Rate: 0.008 or 0.016

Drive Motor: 2 Heavy Duty Hydraulic Motors: 15 gpm @ 1500 psi (57 l/s @ 106 bar)

Finish: Paint, epoxy, utilization of anticorrosive process on other parts.

Weight: 1800 lbs.

Blade: Coarse 98-37-414 For heavy wall or multi-strand pipe.

Fine 98-37-415 For thin wall single strand pipe.

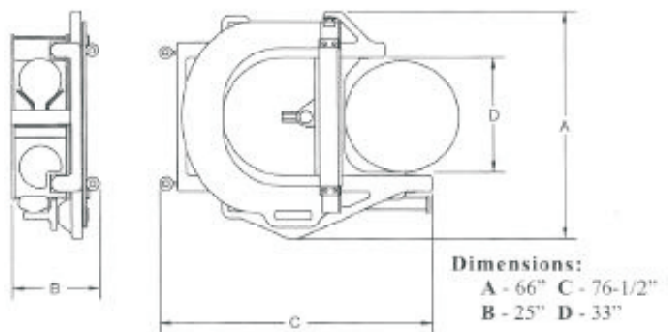

E.H. WACHS COMPANY 100 Shepard St. Wheeling, IL 60090
800-323-8185 in U.S.A. 847-537-8800 Worldwide Fax 800-520-1147
wachsco.com

Gary Herman Companies, LLC.
4706 Curtis Lane
New Iberia, LA 70560
337-367-2880 www.alpha4rentals.com