



LG-1620 OPERATING INSTRUCTIONS

WARNING: To ensure operator safety and efficient operation of the CaviBlaster™, it is essential to follow these instructions.

Preparing the CaviBlaster™ unit:

1. Inspect the CaviBlaster™ power unit, hoses and lance for any signs of damage.
2. Check oil and fuel levels:
Proper oil level in pressure pump (dip-stick in back of pump) (Figure 1). Proper oil level in engine (dip-stick in engine block) (Figure 2). Off-road diesel fuel level (Figure 3).



Figure 1



Figure 2

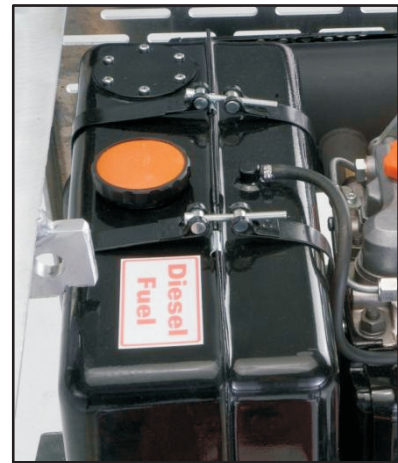

Figure 3

3. Fill lubricating oil(s) to proper level(s) as necessary and per pressure pump and engine manufacturers' operating manuals.
4. When feeding water to the CaviBlaster™ power unit with the feed pump, connect the 1" diameter clear PVC feed hose to the stainless steel cam-lock plug on the pressure pump inlet (Figure 4). The feed hose has the feed pump on one end and a stainless steel female cam-lock on the other end. Insert the electrical plug powering the feed pump into the waterproof electrical outlet next to the battery box (Figure 5). Ensure that the red knob on the plug is facing up and mates with the notch in the outlet cover. **If the plug is engaged upside down, the pump will turn in reverse and will not pump water. Ensure that the feed hose is connected to the pressure pump and that the feed pump is securely submerged in the water source prior to starting the pump.** Either fresh water or seawater can be used with this unit.

When feeding the CaviBlaster™ with an alternate water source, the source must supply water at a volume of greater than 16 gallons per minute at a maximum pressure of 70-psi. Connect the water source to the cam-lock plug on the inlet of the pressure pump (Figure 4). **Ensure that the feed hose is connected to the pressure pump and the water is on prior to starting the pressure pump.**



Figure 4



Figure 5

5. Connect the 1" red rubber bypass hose to the stainless steel cam-lock plug under the pressure regulator (Figure 6). The bypass hose has a stainless steel female cam-lock on one end. Direct the bypass hose away from the working area and secure the hose.
6. Connect the 3/4" black high-pressure hose to the male quick-connect plug on the pressure regulator (Figure 7). The LC-1620 CaviBlaster™ can deliver the required pressure utilizing up to 300 feet of 3/4" diameter hose. [Using greater lengths or smaller diameters of hose may degrade performance.](#)



Figure 6



Figure 7

Starting the CaviBlaster™ unit:

1. Ensure that the feed pump (red) and the pressure pump clutch (metallic) toggle switches located on the battery box (Figure 8) are in the "off" position.
2. Insert the key into the ignition switch on the side of the engine away from the pressure pump. Turn the key clockwise one position to heat the glow plugs (Figure 9). Once the two red lights to the left of the ignition switch are on, turn the key farther clockwise to start the engine.





Figure 8



Figure 9

3. When using the feed pump, start the feed pump by moving the red feed pump switch to the “on” position (Figure 8). When using an alternate water source, start the water supply to the pressure pump.
4. Ensure that the system is primed with water and that there are no leaks in the system. The pressure pump is a positive displacement pump and water must be supplied under pressure. **Failure to pump feed water to the pressure pump will result in damage to the pump.**
5. Connect the lance (Figure 10) to the end of the black high-pressure hose and submerge the lance in the water.
6. The system is now ready to operate.



Figure 10

WARNING: Although the CaviBlaster™ system is safe to use when submerged in water, it generates a high-pressure (up to 2,000-psi) water stream, which can cause injury when out of the water. ALWAYS keep the lance submerged when the pressure pump is on.

Operating the CaviBlaster™ unit:

1. When the diver is ready to commence cleaning operations, ensure that the lance trigger is in the open or “on” position (Figure 11), the lance is submerged in water and the feed pump is operating prior to engaging the pressure pump clutch.
2. Engage the pressure pump by moving the pressure pump clutch toggle switch to the “on” position (Figure 8).



3. The most efficient operating technique is to hold the nozzle 2-3 inches away from the surface to be cleaned and at a 25 to 45 degree angle to the surface being cleaned (Figure 11). Placing the nozzle closer than 2-3 inches from the surface being cleaned will not allow for efficient cavitation performance and will degrade the cleaning capability of the CaviBlaster™ system.

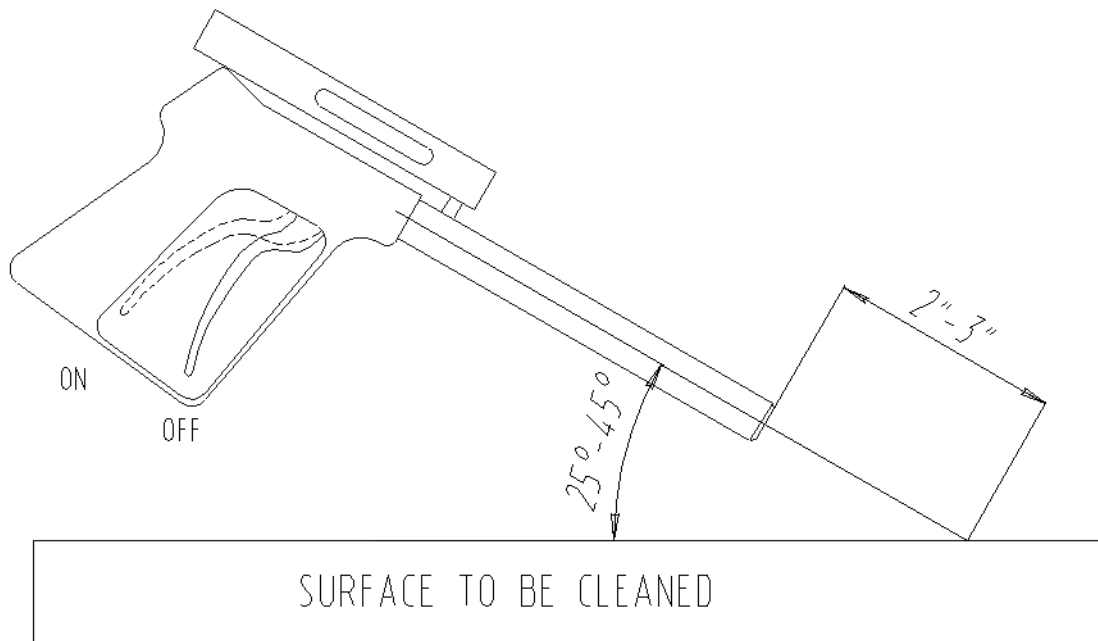

Figure 11

4. Follow all safety regulations that may be applicable to the work being performed.
5. If the diver operating the CaviBlaster™ unit must be replaced or the cleaning operation must be terminated, disengage the pressure pump by moving the pressure pump clutch switch to the “off” position and release the water pressure in the system by moving the lance trigger to the open or “on” position while under water. Revert back to step 1 of the operating instructions when the replacement diver is ready to continue cleaning.
6. Ensure that the lance is submerged any time the pressure pump is operating.

Shutting down the CaviBlaster™ unit:

1. Stop the pressure pump by moving the pressure pump clutch switch to the "off" position.
2. Squeeze the lance trigger to the open or “on” position to release water pressure remaining in the hoses.
3. Stop the feed pump by moving the feed pump switch to the "off" position.
4. Shut down the engine by turning the key in the ignition switch.
5. It is now safe to remove the lance from the water.



Maintenance of the CaviBlaster™ unit:

1. Empty and clean the inline strainer every day.
2. Check the oil levels in the engine, pressure pump and air filter every 8 hours.
3. Inspect the pump drive belts every 150 hours and replace the belts if cracking appears.
4. Change the engine oil, oil filter and fuel filter every 200 hours.
5. Change the oil in the pressure pump every 500 hours.
6. Change the spring for the lance trigger every six months or as required.

Summarizing the operating instructions:

1. Check oil and fuel levels.
2. Inspect all hoses and attach hoses to the unit.
3. Check that both the feed pump and pressure pump clutch switches are in the “off” position.
4. Start the engine.
5. Engage the feed pump or turn on the alternate water supply and ensure that the system is primed with water.
6. Inspect the lance (including the zero-thrust nozzle guard) and attach to the pressure hose.
7. Ensure that the diver is ready to work and the lance is submerged in water.
8. Open the lance trigger.
9. Engage the pressure pump to supply water to the lance.
10. Proceed with cleaning.
11. Disengage the pressure pump.
12. Release pressure from the system by pulling the lance trigger to the open or “on” position.
13. Stop the feed pump.
14. Shut down the engine.
15. Remove the lance from the water.



WARNING

While the CaviBlaster™ system is very safe, operators should exercise care when using the equipment. The cavitation “flame” can be safely passed over the operators’ skin at normal operating distances of 2”– 3” from the tip of the nozzle. However, at very close distances (typically less than 1”) both nozzles are capable of causing harm to the operator, particularly in the initial instant that the system is activated. For that reason, **operators should exercise caution when operating the lance with the nozzles in close proximity to the body. The operators should also ensure that the reverse-thrust nozzle guard is secured in the correct position prior to operating the lance.**

The operators of the CaviBlaster™ system should always wear neoprene or heavy rubber gloves to provide protection to the hands and, in particular, to the nails. The gloves will absorb most of the energy produced by bursting cavitation bubbles and prevent the cavitation bubbles from contacting the operators’ hands. The gloves will also protect operators’ hands from the initial shockwave when the lance is activated.

Serious harm and injury may result from the misuse of CaviBlaster™ system equipment or improperly selected fittings, hoses or attachments. All components of the system should be checked against the manufacturers’ instructions to ensure that they are compatible with the pressures being used and of the correct thread type and pressure rating for the intended service. Refer to these Operating Instructions and to the engine and pressure pump manufacturers’ operation manuals for instructions or call us,

at (337) 367-2880 with any questions.

